



MALTA RESOURCES AUTHORITY

Analysis of Potential for **Co-Generation on the** **Maltese Islands.**

23 June 2009

Contents

Introduction.....	4
1. Current Situation.....	6
1.1 General.....	6
1.2 Energy.....	7
2. Energy Supply and Demand	9
2.1 Electricity.....	9
2.2 Heat.....	9
2.3 Fuel Prices.....	11
2.4 Electricity Prices	12
2.4.1 Commercial Electricity Prices Pre-2008.....	12
2.4.2 Industrial Electricity Prices Pre-2008	15
2.4.3 Fuel Surcharge	16
2.4.4 Revised tariffs from October 2008.....	16
2.4.5 Export Electricity Tariffs	19
2.4.6 Projected Electricity Tariffs	19
2.5 Power Plant Details.....	20
2.6 Duty on Fuels and Electricity:	21
2.7 CHP Electricity Tariffs in other Member States.....	21
2.8 Other indicators for CHP units.	23
3. Potential of the Residential Sector.....	24
4. Potential in the Commercial Sector	25
4.1 Data.....	27
4.2 Electricity price.....	27
4.3 Fuel Price	27
4.4 Analysis.....	28
4.5 Hotel Sector Conclusions.....	43
5. Potential in the Industry Sector.....	45
5.1 Data.....	45
5.2 Electricity price.....	45
5.3 Fuel Price.	46

5.4	Analysis.....	46
5.5.	Industrial Sector Conclusions	47
6.	Potential of the Educational Sector.....	50
6.1	Analysis.....	50
6.2	Conclusion	50
7.	Potential of the Health Care (Hospital) Sector.	52
7.1	Electricity and Fuel Prices	52
7.2	Analysis.....	52
7.3	Hospital Sector Conclusion.....	55
8.	Potential of the Waste Sector.....	57
9	The Use of Absorption Chillers	58
10.	Conclusions.....	60

Introduction.

The Co-generation Directive 2004/8/EC was transposed into Maltese Legislation through Legal Notice No. 2 of 2007 (as amended by Legal Notice No. 196 of 2008). The purpose of this Directive is to promote the use of high efficiency co-generation. In co-generation or as it is normally called Combined Heat and Power (CHP) heat and electricity are produced simultaneously in one process. Heat from hot water, steam or exhaust gases is recovered following electricity generation for a more efficient use and hence less harm to the environment.

In separate electricity and heat generation the conversion efficiency is between 35 to 55 per cent, but in CHP plants overall efficiency is as high as 80 to 90 per cent. This is achieved by using unused thermal energy following work to generate electricity in industrial processes or district/leisure industry heating requirements. These energy savings i.e. this increase in energy efficiency, reduces greenhouse gas emissions and equally, or more importantly, if the selection of the equipment is done well, could lead to a positive economic return in view of the ever increasing prices of petroleum based electricity energy generation.

Further, decentralised electricity generation, or generation next to the actual load reduces the electricity distribution losses, or energy wasted in the distribution to service a location at a distance from the power plant generation source.

Regulation 6 of the above mentioned Legal Notice obliges the Malta Resources Authority to draw up a CHP feasibility study every four years. In terms of the regulation the study is to:

“(a) be based on well-documented scientific data and comply with the criteria listed in Fourth Schedule;

(b) identify all potential for useful heating and cooling demands, suitable for application of high-efficiency cogeneration, as well as the availability of fuels and other energy resources to be utilized in cogeneration;

(c) include a separate analysis of barriers, which may prevent the realization of the national potential for high-efficiency cogeneration. In particular, this analysis shall consider barriers relating to the prices and costs of and access to fuels, barriers in relation to grid system issues, barriers in relation to administrative procedures, and barriers relating to the lack of internalization of the external costs in energy.”

This first study makes an attempt to explore the possibilities of CHP in the Residential, Educational, Hotel, Industrial, Healthcare and Waste sector. The first chapter of the study presents general information on the energy sector and electricity market of the Maltese Islands, in order that the reader could understand the background in which the investors in CHP would be analysing the feasibility of their project. Each sector mentioned is treated separately. In the final chapter conclusions are made based on the analysis of the different sectors, highlighting the current barriers and suggesting future solutions to make CHP economically feasible in all situations that have positive Primary Energy Savings.

1. Current Situation.

1.1 General. Malta is situated in the central Mediterranean Sea, some 93 km south of Sicily. Only the three largest islands: Malta Island (Malta), Gozo (Għawdex), and Comino (Kemmuna) are inhabited. The smaller islands, such as Filfla, Cominotto and the Islands of St. Paul are uninhabited.

Malta's weather and climate are strongly influenced by the sea and have a very characteristic Mediterranean flavour, similar to that found in southern Italy or southern Greece.

The climate is typically Mediterranean, with hot, dry summers, warm and sporadically wet autumns, and short, cool winters with inadequate rainfall. Most of Malta's rain falls during autumn and winter, mostly from thunderstorms which make up the bulk of the rainfall from September to December. Nearly three-fourths of the total annual rainfall of about 600 millimetres (24 inches) falls between October and March; June, July, and August are normally quite dry. Sometimes weather gets rather windy for up to 3 days with strong gale force winds blowing either from the Northwest (Malta's most prevailing wind) or from the Northeast bringing days of stormy weather.

The temperature is very stable, the annual mean being 18°C (64°F) and the monthly averages ranging from 12° C (54°F) to 31°C (88°F). Winters are mild with only rare occurrences of cold weather brought by North and Northeast winds from central Europe. In fact, daytime winter temperatures almost never fall below 10°C (50°F), while night-time winter temperatures never fall below 0°C (32°F). It is usually mild in Malta during the winter, with plenty of sunshine, too, with daytime temperatures usually 15°C (59°F) or above and sometimes also around 20°C (68°F). Summers are warm, dry and very sunny. The weather usually shows signs of warming up in May, heralding in a long spell of hot, dry weather. Malta's summer temperatures are usually above 30°C (86°F) and

quite often also above 35°C (95°F). Meteorological data show that temperature in Malta generally reaches its peak in the month of August whilst the lowest minimum temperature occurs in February.

Malta has over 400,000 inhabitants which makes it one of the most densely populated States worldwide and has limited natural resources. Its major resources are limestone, a favourable geographic location, and a productive labour force. Malta produces only about 20per cent of its food needs, has limited freshwater supplies, and has no domestic energy sources. The economy is dependent on foreign trade (serving as a freight trans-shipment point), manufacturing (especially electronic industry), and tourism. Tourism infrastructure has increased dramatically over the years and a number of quality hotels are present on the island. Oil exploration is always on the agenda of Maltese Governments.

1.2 Energy. Energy in Malta is derived from the importation of various fossil fuels, since the country has no fossil-fuel resources. Malta is wholly dependant on imported fossil fuels for energy production and extremely vulnerable to exogenous upward fuel price shocks. Upward fuel price movements were being absorbed by the general public, in the form of a fuel surcharge.

Electricity is generated by two power stations, one in Marsa and the other in Delimara, using fuel oil and gas oil. The conversion efficiency varies according to the generating units.

Malta makes minimal use of renewable energy sources when compared to total fuel consumption. According to Directive 2001/77, which Malta transposed by LN 86 of 2004, Member States have to establish targets achievable by 2010. Malta has set an indicative target of five per cent renewable electricity target. The five per cent value was made on the basis of an estimated gross national electricity consumption of 2TWh in 2010 and is subdivided as follows:

- 1.93 per cent of total electricity demand for 2010 generated from wind (15 MW for an annual electricity production of around 39 GWhrs /annum in 2010);
- 3 per cent of 2010 electricity demand generated from biomass (equivalent to around 60 GWhrs/annum in 2010).

Furthermore, according to the new directive for the promotion of the use of energy from renewable sources (Directive 28/2009), Malta has to reach a final target share of 10% of energy coming from renewable resources from its final consumption by 2020.

2. Energy Supply and Demand

2.1 Electricity. On the Islands there is only one electricity generating company, Enemalta Corporation. Enemalta has a total generating capacity of 571 MW, produced by two-oil fired power stations based at Marsa and Delimara which are interconnected by means of the existing grid. Energy statistical data for Malta shows that there has been a continuously increasing demand for electrical energy during the past years. The daily electricity demand for Malta exhibits a pattern that is typical of the Mediterranean region. Peak demand in winter is during the evening and is therefore predominantly domestic. In summer peak demand occurs during late morning and is therefore predominantly commercial and industrial. Table 1 below gives an overview of the maximum demand of electricity over the 1990-2007 periods. The table clearly shows that April, May, October and November are the periods during which there is less demand for electricity. By contrast, February and August are the months when peak electricity demand has been registered. The demand for electrical energy in the islands is increasing constantly from year to year. In fact, average electrical demand from 1990 to 2005 has escalated, from 187.5 MW to 363 MW, a difference of 175.5 MW. It is evident that between 1990 and 2005, Malta's gross energy consumption increased by 73 per cent, with the domestic sector absorbing around 36 per cent of total electrical consumption. The commercial and industrial sectors are the next major consumers of electricity in the islands, with the commercial sector absorbing 33 per cent and the industrial sector 29 per cent. Such a distribution is mainly attributable to accelerating energy demand by the economic sector.

2.2 Heat. Table 2 shows the consumption figures since 2000. Currently Fuel Oil and Gas Oil are mainly used by the Power Sector. The Commercial and Industrial sector uses Light Heating Oil, Thin Fuel Oil or Diesel to cater for its heat requirements. Heat requirements are most in the vast majority by conventional boilers, to date there is no CHP installed on the Islands.

Table 1. Monthly Electricity Peak in MW

Month	1990	1995	1996	1997	1998	1999	2000	2001	2002	2003	2004	2005	2006	2007
January	214	321	284	288	302	309	354	314	369	358	369	389	383	337
February	197	277	312	294	282	353	322	326	319	395	361	402	377	341
March	193	261	314	294	295	287	307	297	299	345	345	378	341	336
April	169	244	229	268	259	245	253	266	284	303	301	316	281	307
May	163	219	220	236	239	257	257	275	271	282	286	311	332	320
June	171	241	242	272	272	282	290	313	344	379	356	378	395	418
July	179	259	269	281	297	299	322	348	359	395	387	403	405	434
August	180	257	275	273	278	311	333	342	367	397	386	411	400	426
September	184	243	265	269	285	307	329	340	324	390	366	377	365	376
October	188	240	238	257	262	275	283	312	312	338	326	324	349	345
November	182	260	254	249	293	285	276	290	296	304	319	313	314	329
December	230	265	280	286	315	322	287	361	332	362	357	354	321	366

Table 2. Fossil Fuel Imports in tons.

Fossil Fuel Imports - Metric Tons								
	2000	2001	2002	2003	2004	2005	2006	2007
Gas Oil	170,721	45,619	53,420	71,672	22,228	67,731	43,631	53,704
Diesel (low sulphur)	0	111,767	56,617	109,550	137,851	97,710	91,826	99,188
Unleaded	27,220	29,172	43,577	70,186	58,012	68,028	75,982	63,866
Premium	42,692	37,501	31,113	0	0	0	0	0
Kerosene	9,677	9,992	12,386	14,719	15,640	3,000	1,878	1,413
Jet A-1	133,740	89,070	87,083	76,602	98,284	85,138	75,164	86,678
Aviation Gasoline	135	133	160	98	129	151	110	84
Fuel Oil	428,318	545,894	529,323	547,826	577,440	607,644	592,197	637,360
Light Heating Oil	0	3,000	3,098	3,783	7,274	15,789	12,862	11,147
LPG	16,135	16,383	17,369	16,997	16,816	18,177	19,597	19,759
Propane	224	131	123	318	195	421	336	228

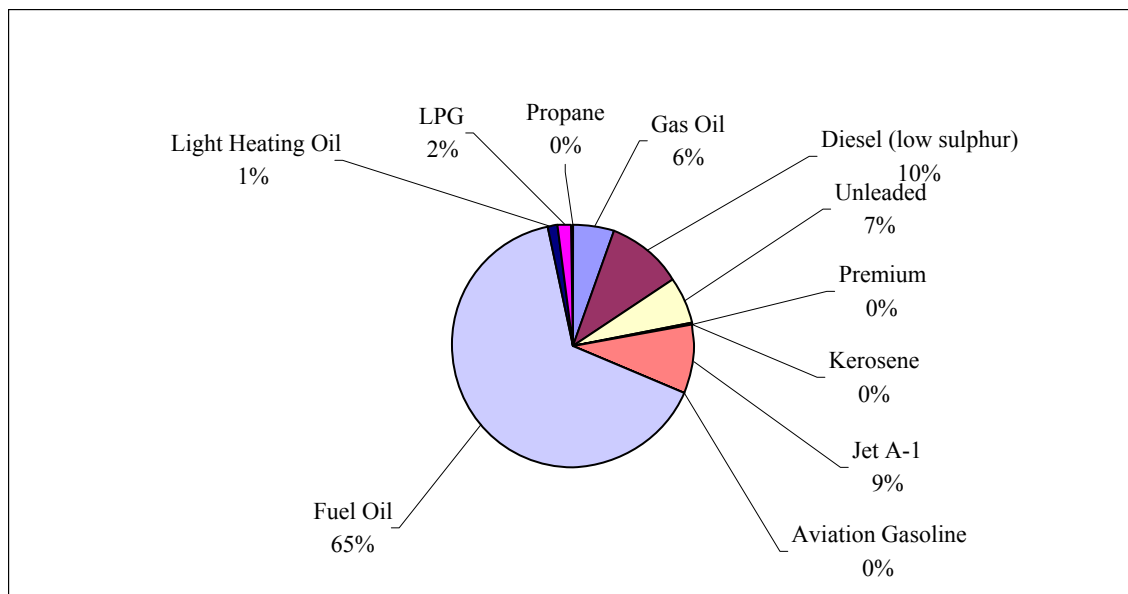

Chart 1. Fossil Fuels Importation Percentage Importation in 2007

2.3 Fuel Prices

Local fuel prices for 2006 onwards are shown in the Tables 3 and 4:

	Unleaded	LRP	Diesel	Kerosene	LHO
	€/Litre	€/Litre	€/Litre	€/Litre	€/Litre
Jun - 06	1.16	1.23	1.02	1.01	0.63
Jun - 07	1.06	1.13	0.92	0.93	0.56
Jun - 08	1.20	1.27	1.21	1.3	0.93

Table 3

	Average Price in € per Metric Tonne		
	2006	2007	2008
Thin Fuel Oil 200 deg	361.15	326.20	451.60
Thin Fuel Oil 450 sec	345.33	325.62	443.06
Thin Fuel Oil 950 sec	328.63	308.63	430.94

Table 4

Local gas prices are indicated in table 5:

LPG	Price in € per Cylinder	Propane	Price in € per cylinder
10 Kg	4.8	10 Kg	7.8
12 Kg	5.7	12 Kg	9.36
15 Kg	6.73	15 Kg	11.72
25 Kg	12.00	25 Kg	19.45
Bulk / Kg	0.466	Bulk / Kg	0.792

Table 5

2.4 Electricity Prices

Electricity prices were reviewed and changed by Enemalta Corporation in the last quarter of 2008. This study will analyse CHP feasibility scenarios with (i) the pre-2008 energy market conditions and (ii) with varying scenarios under the 2009 market conditions.

2.4.1 Commercial Electricity Prices Pre-2008

Commercial consumers could choose to be billed either in kWh or kVAh. Prices for kVAh are cheaper in order to encourage consumers to install power factor correction equipment. The electricity prices for commercial entities were divided into two categories, those related to Hotels & Guesthouses and those related to Commercial activities. These are explained respectively in Table 6a and Table 6b below. To note that government institutions are also considered as commercial activities. The fuel surcharge defined is that set effective on July 2008.

		Type of premises (Tariff C1)		Meter Rent	Consumption Charge		Fuel Surcharge
Commercial	Tariffs Exclusive of VAT	All (including garage, marine, craft, temporary installations, street lighting but excluding hotels and guesthouses)	Option 1: Tariff measured in kWh	€55.90 per annum	0 -200 units	Free	A 95% surcharge on the net billed consumption of water and electricity is applicable for the period December 2007 to June 2008
					more than 200 units	8.6 per kWh	
		Option 2: Tariff measured in kVAh (applicable only if consumption is >100 A/Phase)	€55.90 per annum	all units	7.9 per kVAh		

Table 6a. Commercial Electricity Rates

		Type of premises (Tariff C2)		Meter Rent	Consumption Charge		Fuel Surcharge	
Commercial	Tariffs Exclusive of VAT	Hotels & Guesthouses	Option 1: Tariff measured in kWh	€55.90 per annum	0 -200 units	Free	A 95 % surcharge on the net billed consumption of water and electricity is applicable for the period between December 2007 and June 2008	Consumption p.a. ≤ €23294; Surcharge ≤€14675p.a
					more than 200 units	8.4 per kWh		Consumption p.a. >€23294 but <€46587; Surcharge ≤€19567p.a
			Option 2: Tariff measured in kVAh (applicable only if consumption is >100 A/Phase)	€55.90 (Lm 24) per annum	all units	7.7 per kVAh		Consumption p.a.> €46587 but <€69881; Surcharge ≤€29350p.a
								Consumption p.a.>€ 69881 but <€ 93175; Surcharge <€ 39133=p.a.
								Consumption p.a.>€ 93175 but <€ 116469; Surcharge ≤€48917p.a.
								Consumption p.a.>€ 116469 but <€ 232937; Surcharge ≤€ 58234p.a.
								Consumption p.a.>€ 232937 but <€349406; Surcharge ≤€68484=p.a
								Consumption p.a.>€ 349406; Surcharge ≤€

2.4.3 Fuel Surcharge.

To cover for the increase in fuel prices the electricity company had introduced in the electricity bill a fuel surcharge on the billed consumption of electricity. This surcharge commenced at 47.5% as from the 1st January 2006 and was being revised on a bi-monthly basis to reflect international fuel price fluctuations. As stated in previous paragraphs the fuel surcharge was capped for some commercial accounts, i.e. those of hotels and guest houses, and for industry. The fuel surcharge in 2007 varies between 54 and 45 per cent, and was set to 95% effective on July 2008. The new tariff system described below does not make use of the fuel surcharge mechanism.

2.4.4 Revised tariffs from October 2008.

As described earlier Malta's electricity generation is mainly derived from imported fossil-fuels, mainly heavy fuel oil (HFO) and gas oil. Equally important we have to note that potable water generation is mainly produced from reverse osmosis plants which run on electricity. Due to the high increase and volatility of the fossil fuel oil prices in 2008, the tariff system described earlier based on a fixed tariff with additional variation of a fuel surcharge, had to be reviewed as a way how to improve on the distribution of costs between the various sectors, both for electricity and water supplies. The Government has conducted a study in order to share the burden of the increase in fossil fuel costs and energy evenly among sectors and to introduce eco incentives for the domestic consumers who manage to use their resources efficiently.

The tariffs introduced, now differentiate between Residential and Non-residential, residential being the sector which before was defined as domestic, whereas the non-residential involves the rest. This change however introduced a sharp increase in tariffs for the Non-residential sector which mainly controls the economy of the island and for which there was a concern as regards to planned and projected activities and future pricing of such industries. For instance, the hotels sector had already issued their pricing brochures for the two year ahead without projecting this sudden rise in energy cost.

Hence the Government agreed that certain sectors, mainly hotels, guest houses, factories of relatively high manufacturing operations and water generation from the national water supplier; will adapt a reduced tariff rate which will be reviewed and increased in steps such that this rate will reach gradually the actual rate.

The Non-residential sector may also benefit from cheaper tariffs if they qualify within set criteria. These include a VoltAmpereHour measure and cheaper tariff rates as against Watt-Hour, by the inclusion of power factor correction equipment aiding in reducing in the distribution losses for the supplying utility; and Day and Night tariff as an incentive to shift some electricity load operations during the night and hence help in the power plant peak load shaving, given that at night the demand is low and some plant generation is still required as reserve and since in some cases it is non-economically feasible to cycle shut down during the night, and re-starting in the day.

Below one may find the criteria and the tariffs as reviewed, and starting from 1st October 2008.

kVAh:

Non-Residential Services having more than 100Amps per phase are eligible to a kVAh tariff. This requires power factor correction equipment investment, but improves the efficiency of the power distribution. Hence the tariff rate is lower than the normal kWh rate to promote this energy efficiency measure.

Night & Day Tariff:

Non-Residential Services consuming more than 5,000,000 kWh or 5,500,000 kVAh may be eligible to a Night and day tariff, being more expensive during the day from the normal tariffs and cheaper during the night from the normal tariff. The Day Tariff is measured from 06:00hrs to 22:00hrs (16hours) whereas the Night Tariff is measured from 22:00hrs to 06:00hrs (8hours). This measure is taken as to promote the activity shift during the night since at night most of the Power Stations' machinery is running at a lower load and so with less efficient.

Reduced Rate:

Some sectors have been entitled to a Reduced Rate in order to ease the transition of the removal of the old tariff mechanism and the fuel surcharge to the new tariff.

Reverse Osmosis plants operated by Water Services Corporation, Hotels and Guest Houses will benefit from this reduced rate. Factories may benefit from these reduced rates if they have an annual estimated consumption of 1,200,000 kWh or 1,300,000 kVAh for kWh metering or kVAh metering respectively.

Bands Non-Residential (kWh)	Consumption Units (kWh)	Reduced Rate excl. VAT (€)	Reduced Day & Night rates excl. VAT	
			Day (€)	Night (€)
Band 1	First 2,000	10c4	10c6	9c9
Band 2	Next 4,000	11c2	11c4	10c7
Band 3	Next 4,000	12c5	12c7	12c0
Band 4	Next 10,000	14c0	14c2	13c5
Band 5	Next 40,000	15c7	15c9	15c2
Band 6	Next 40,000	14c2	14c4	13c7
Band 7	Next 900,000	12c9	13c1	12c4
Band 8	Next 4,000,000	11c2	11c4	17c7
Band 9	Next	8c6	8c8	8c1

Bands Non-Residential (kVAh)	Consumption Units (kVAh)	Reduced Rate excl. VAT (€)	Reduced Day & Night rates excl. VAT	
			Day (€)	Night (€)
Band 1	First 2,000	9c6	9c8	9c1
Band 2	Next 4,000	10c3	10c5	9c8
Band 3	Next 4,000	11c5	11c7	11c0
Band 4	Next 10,000	12c9	13c1	12c4
Band 5	Next 40,000	14c4	14c6	13c9
Band 6	Next 40,000	13c1	13c3	12c6
Band 7	Next 900,000	11c9	12c1	11c4
Band 8	Next 4,000,000	10c3	10c5	9c8
Band 9	Next	7c9	8c1	7c4

Table 8

2.4.5 Exported electricity tariff.

In case of uncentralised electricity generation from renewable sources, the policy adopted today is that of net metering i.e. the excessive power transfer to the grid is deducted from the metered consumed power. However in the case that the overall power transferred to the grid in a year is more than metered consumption, the excess delivered to the grid, called spill-off, is attributed the value of 0.06988€/unit. After the revision of the tariffs effective in October 2008, the spill-off tariff was not changed. It is not excluded that the policy of net-metering is changed to a feed-in tariff, having tariffs depending on the technology used to generate electrical power.

2.4.6 Projected electricity tariffs

For this study three scenarios were analysed for the projected ‘future’:

- (i) Scenario 1 - a business as usual scenario were the electricity export rate is assumed 6.988 €cents and a net metering system applied where the CHP electricity generator is only paid for the electricity it exports and pays at its standard rate any imports of electricity it requires extra besides the displaced electricity from its own CHP generation;
- (ii) Scenario 2 - a ‘total feed in tariff’ scenario were the electricity export rate is again assumed 6.988 €cents however in this scenario the CHP electricity generator exports all the electricity it generates and imports all electricity required at its standard electricity rate;
- (iii) Scenario 3 - a scenario similar to (ii) however this time the electricity export rate has a bonus price of 1 €cent/kWh.¹ on market price.
- (iv) Scenario 4 – scenario similar to (ii) however in this scenario only 50% of the electricity exported to the grid is paid at bonus price of 1 €cent/kWh on market price.

2.5 Power Plant Details:

As indicated in Section 2.1, Malta has two power plants in different parts of the Island, operated both by Enemalta Corporation. For this study the current situation of the power plants has been considered, and since the analysis averages data on a yearly basis, the average efficiency of the plant on a yearly basis has been taken. For future projections, since the most inefficient plant will be phased out, the efficiency figures of what may be the future scenario of plant generators has been assumed. Technical transmission losses are quoted by Enemalta Corporation as 5 per cent. Other non accounted losses have not been considered in this study as introduction of CHP would not affect these losses. Table 9 summarizes the figures taken.

	Pre-2008	Future
Power Plant efficiency	27.7 %	31.4 %
Transmission losses	5 %	5 %

Table 9

¹ The feed in tariff bonus price is a bonus added to the market electricity price paid by the CHP generator for each kWh of electricity they generate. In Portugal the bonus price have been introduced for micro CHP generation, applicable to 50% of the electricity generated. The bonus prices are differentiated according to technology type, Otto cycle engines receive a bonus price of 1 €cent/kWh.

2.6 Duty on Fuels and Electricity: Latest duties on fuel and generation of electricity are indicated in Table 10.

Gas Oil for heating purposes	€cents 14.21 per litre
Gas Oil for electricity generation	Nil
Heavy fuel oil	€ 13.98 per ton
LPG	€ 34.95 per ton
Electricity	€ 0.84 per MWh

Table 10

As in the past years excise duty on generated electricity and fuel for electricity generation apart from upon the main electricity provider was not imposed by the Customs this was not used in the pre-2008 scenarios. In future scenarios considered the above customs regime is considered to be enforced and hence is applied in this exercise. Hence for the future scenario no duty is applied on generation fuel and minor duty is applied on electricity generated.

2.7 CHP Electricity Tariffs in other Member States. European States promote the use of CHP in different manners, hereunder is an indication of these measures.

Denmark. Until 2005 all CHP operators aside from large central CHP plants, benefited from customers on the local distribution network have an obligation to buy the electricity produced by local CHP units. Currently CHP burning woodchip, straw or biogas has a feed in tariff ‘premium’ plus the market price. This price varies from €c5 to €c8 per kWh.

Finland. This State has achieved a high level of CHP utilisation with little direct intervention of the government possibly due to the high requirement of district heating required. In the electricity market there was never an obligation to purchase electricity

generated from CHP. In Finland the tax regime on fuels is used to drive the operators of CHP plants to use renewable fuels and fuels with low carbon content. Natural Gas receives a fifty per cent rebate on the CO₂ tax and peat receives complete exemption.

Germany. In Germany a 2002 law has helped drive CHP with a premium payment with electricity from CHP plants being modernised, and CHP plants less than 2MWe. Germany also gives tax exemption to natural gas and heating oil used for CHP, and high feed in tariffs for biogas CHP. The electricity price bonus is €c 2.1 /kWh for new small plants less than 2 MWe and €c 5.1 for plants less than 50kWe².

United Kingdom. The United Kingdom has taken powers in the Energy Act 2008 to allow feed in tariff for electricity from small scale CHP under 50kWe, however no system has been set up yet. Above 50kWe the UK already uses a mixture of preferential treatment in the EU Emissions Trading Scheme and the carbon trading systems such as the Carbon Reduction Commitments and tax breaks (Enhance Capital Allowances and Climate Change Levy).

Portugal. The Portuguese Co-generation Law has provided a feed in tariff stimulated interest and a steady growth of CHP. In 2003 distributed generation, of which CHP represented approximately 80%, accounted for about 12 percent of the electricity production. CHP plants must achieve a minimum Electrical Equivalent Efficiency (EEE) taking in account both the heat and electrical efficiency, to qualify for support through Law. The EEE varies from >55% when CHP uses Natural gas, LPG or liquid fuels excluding fuel oil or >45% when the CHP uses biomass. The support is given through the feed in tariff and usually takes form of a bonus added to the market electricity price paid to the CHP plant operators for each kWh of electricity they generate or export to the grid. The Bonus Prices for micro CHP electricity exported to the grid are applicable for 50% of the electricity generated and varies according to the technology type. Emerging technologies receive higher payments than established technologies. Prices are paid on

² This rate is for 10 years after becoming operational.

the base value for the electricity and vary from €1c/kWh for diesel engines to €20c/kWh for Photovoltaics.

2.8 Other indicators for CHP units. In order to compute the ‘payback period’ and the ‘primary energy saving’ a number of indicators had to be assumed. These indicators related to technical specifications of CHP equipment were forwarded to the Malta Resources Authority by the grateful collaboration of CHPQA Programme under the authorisation of the UK Department of Energy and Climate Change. The main indicators were (i) the cost per kW of CHP units, (ii) the efficiency of conventional boilers was taken as 75 per cent, (iii) the electrical efficiency of the CHP equipment is approximately 35 per cent (depending on the size of the machine), (iv) the power to heat ratio of the preferred engine for each specific case was taken from a straight line when plotting actual ‘power to heat’ figures to ‘heat demand’, (v) when using the chart described in (iv) figures for head demand less than 105 kWth had to be obtained by extrapolating the straight line³ and (vi) in cases where heat is required for the whole year (i.e. 8760 hrs.) the CHP runs for 95 percent of the year. When considering ‘near future’ fuel prices these were assumed to be equal to the average for 2009.

³ This assumption affected Category C Hotels (See Table 11) and the Hospital with a low power to heat ratio (See section 7).

3. Potential of the Residential Sector.

As already stated the mean temperatures of the winter period and the summer period indicate that the (i) housing heating period is only between mid December to mid February and mainly in the night period, and (ii) the cooling period runs between mid May to September. Thus the heating/cooling period is around seven months a year. These figures already could indicate that cogeneration could not be viable due to the restricted heating/cooling requirement however the barrier in this sector is also technology. The fact that piped natural gas is not available to the residential sector the choice for a micro CHP unit is restricted to diesel engines which could prove non-financially feasible due to both initial and operating costs.

A more financially viable solution to address the annual heating requirements of a residence would be solar thermal. And if absorption residential air conditioning systems would be in the reach of the general population's pocket this technology in liaison with a solar thermal panel could address the summer months cooling load. With these ideas in mind CHP is not seen as currently feasible for the residential sector of the Maltese Islands.

4. Potential in the Commercial Sector

In Malta, within the commercial sector it is the Hotel industry which requires a significant heat load hence the study will be referring to the feasibility of implementing CHP in the Hotel sector. This sector is quite important to the national economy, since the tourism industry is one of the most important financial income to our economy. The study may further be extended to apartments having common facilities managed by a common service provider, if this will be the way forward for building regulations. However the study will concentrate on the Hotel industry, for which data was available to the Malta Resources Authority.

Cogeneration may be considered as an energy efficiency measure, even though energy is generated by conventional fossil fuel and thus cannot be considered as a renewable energy resource, unless alternative combustion material, as waste, is used. This is not the case for the Hotel industry. CHP, could be advantageous in the Hotel industry since it can produce heat and electric power at the source of the load requirements, and assuming that a Diesel engine coupled with an electric generator is used for CHP, the over all efficiency of energy generation is way above that of energy transfer from the Power Station, considering a Power Station average efficiency of 27.7 per cent and transmission technical losses of 5 per cent⁴.

As stated in section 3, Malta does not have either a gas network or municipal heating distribution, furthermore the hotels in Malta, from the particular load profiles retrieved, show a constant heat requirement through out the year with an extensive higher demand in the cold period, normally from December to March, and then an extensible requirement of electrical power for cooling purposes between May and October. Chart 2 shows a particular profile.

⁴ The 5 per cent is the technical transmission loss of the Enemalta Electricity Grid.

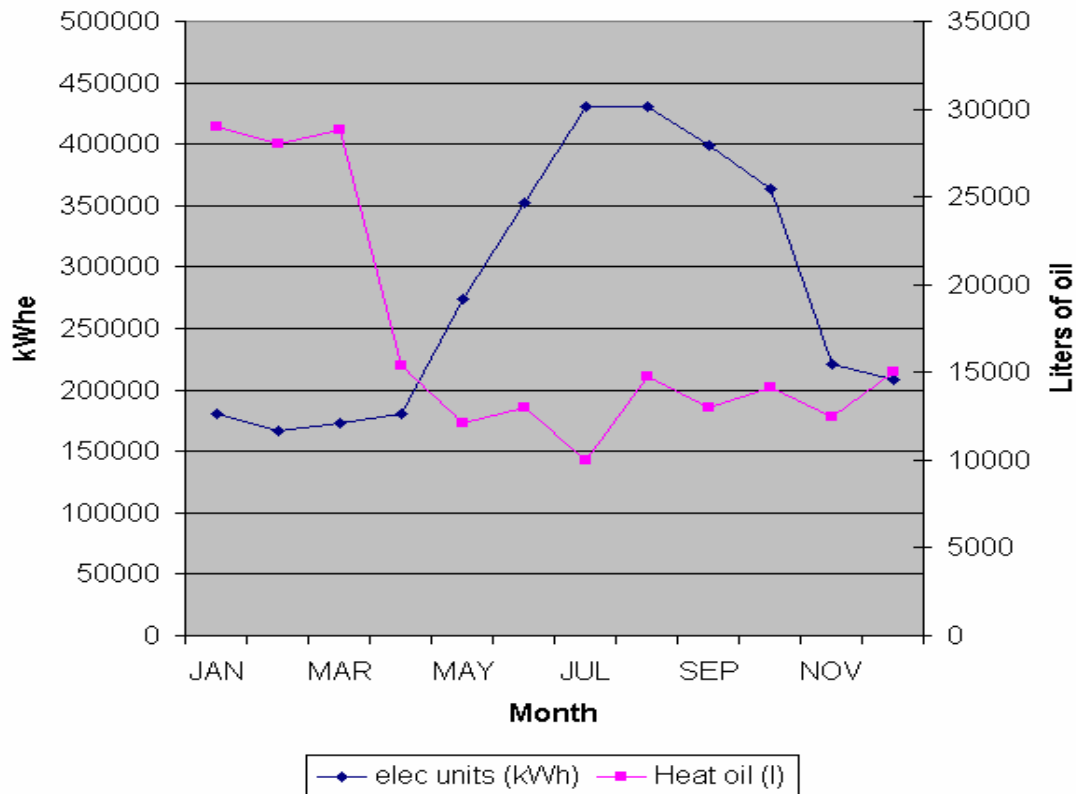

Chart 2. Energy Load profile of a typical Hotel

The above profile would suggest the use of absorption chillers to generate cool environment from a heat source. Absorption chillers are analyzed in Section 8. For the rest of this section the heat sources considered were either conventional boilers or the CHP, i.e. no consideration is taken in account in deriving heat from a renewable energy source, as solar heat concentrators, since it is not the scope of this report.

For this analysis, it was decided that the Hotels sector be divided into various categories and that these will be categorized by the number of rooms. For this analysis 3 representative hotels for each category were considered. The categories were subdivided in this manner:

Category A	more than 250 rooms	
Category B	more than 150 rooms	less than 250 rooms
Category C		less than 150 rooms

Table 11. Hotel Categories as divided for the study

4.1 Data. Several Hotels supplied the consumption data for heating fuel and electricity consumption with the cost for consumption figure, the type of fuel used and the main application, the number of rooms and the operating days. Fuel/Heating used for cooking is not being considered as on the Maltese Island the fuel used on Liquefied Petroleum Gas which is supplied by cylinder or bulk.

The analysis considers the pre-2008 situation, of the fuel prices and electricity tariffs, based on the pre-2008 data provided by each Hotel, assuming that the consumption requirements did not change, and further the analysis considers the predicted fuel future with the extrapolated and projected figures, also based on the pre-2008 consumption figures.

4.2 Electricity price. The electricity tariffs for the Hotel sector can be viewed from Section 2.4.1. However since the over all net unit price may vary from hotel to hotel depending on their consumption, from the data acquired for 18 hotels, the average price per unit was calculated, and further diversified by category. The Table 12 below shows a summary of the electricity prices for each Category. Near future electricity pricing are as explained in 2.4.5.

4.3 Fuel Price. The fuels available for Hotels in the pre-2008 scenarios where as described in Table 13. However when considering fuel prices for Analysis 1 in Section 4.4 only one price was used, that is, € 79.03 per MWh, which was calculated from data given by the specific hotel analyzed. As regards to near future projections, a new regulation is being processed to eliminate high sulphur fuel from the market and make available Gas Oil at 0.1per cent sulphur content, with a rebate on excise duty when used

for conventional heating purposes. As detailed in Table 10, gas oil for electricity generation, including CHP, is duty free. In the near future projection, this is the fuel considered for both conventional boilers and diesel driven CHP.

	Average pre-2008 Unit Electricity price (€)	Near Future Unit Electricity price (€)
Category A	0.1030	0.1158 Or 0.1222 ⁵ .
Category B	0.0825	0.1222
Category C	0.1270	0.1331

Table. 12 Pre-2008 and Future electricity prices for the Hotel Industry used in this study

	Pre-2008 Fuel price (€/liter)	Near Future Gas Oil 0.1 % Sulphur (€/liter)	Near Future Gas Oil 0.1 % Sulphur (€/liter)
			Excise Duty Free
Diesel	0.95 ⁶	0.68	0.58
LCO	0.8789	None	None

Table. 13 Pre-2008 and Future fuel prices for the Hotel Industry used in this study

4.4 Analysis. The analysis has been done on two fronts:

Analysis 1) Taking a specific Hotel case profile and investigating the several of scenarios for pre 2008 and scenario 1 with 2009 prices.

a) Annual average normalized.

⁵ Electricity Tariff depends on consumption. Tariff are based on annual average consumption.

⁶ Though there were fluctuations in price for diesel in the last quarter, 0.95 €/liter is being considered an average price for diesel.

- b) Utilizing CHP only during cold season, the boiler used for the rest of the year.
- c) Utilizing CHP for the excessive heating requirement over the boiler supplying the heat base load.
- d) Utilizing a boiler for the excessive heating requirement over the CHP supplying the heat base load.

Analysis 2) Taking the three categories of hotels on an annual average consideration for the pre-2008 and future scenarios.

Tables 14 to 26 show the results of CHP feasibility for the above mentioned situations.

Annual Fuel Input	2289	MWh
Heating Season (incl. boiler produced LTHW)	8760	hours
Annual Electricity consumption	6800	MWh
Operating hours / year	8760	hours
Electricity Price	€ 107.50	€ / MWh
Fuel Price	€ 79.03	€ / MWh
Electricity export price	€ 69.88	€ / MWh
CHP availability	95per cent	
O&M	€ 13.00	€/MWh
CHP Fuel	€ 93.42	€/MWh

Payback Period	CHP making loss	Years
Energy Saving	3297.61	MWh

Table 14. Case 1a. Specific Hotel annual average normalized for Pre-2008. CHP running on G/Oil.

Annual Fuel Input	2289	MWh
Heating Season (incl. boiler produced LTHW)	8760	hours
Annual Electricity consumption	6800	MWh
Operating hours/year	8760	hours
Electricity Price	€ 115.79	€ / MWh
Fuel Price	€ 66.55	€ / MWh
Electricity export price	€ 69.88	€ / MWh
CHP availability	95 %	
O&M	€ 13.00	€/MWh
CHP Fuel	€ 57.01	€/MWh

Payback Period	1.81	Years
Energy Saving	2752.88	MWh

Table 15. Case 1a. Specific Hotel annual average normalized, near future prices. CHP running on Gas Oil. Electricity export price based on a net metering scheme.

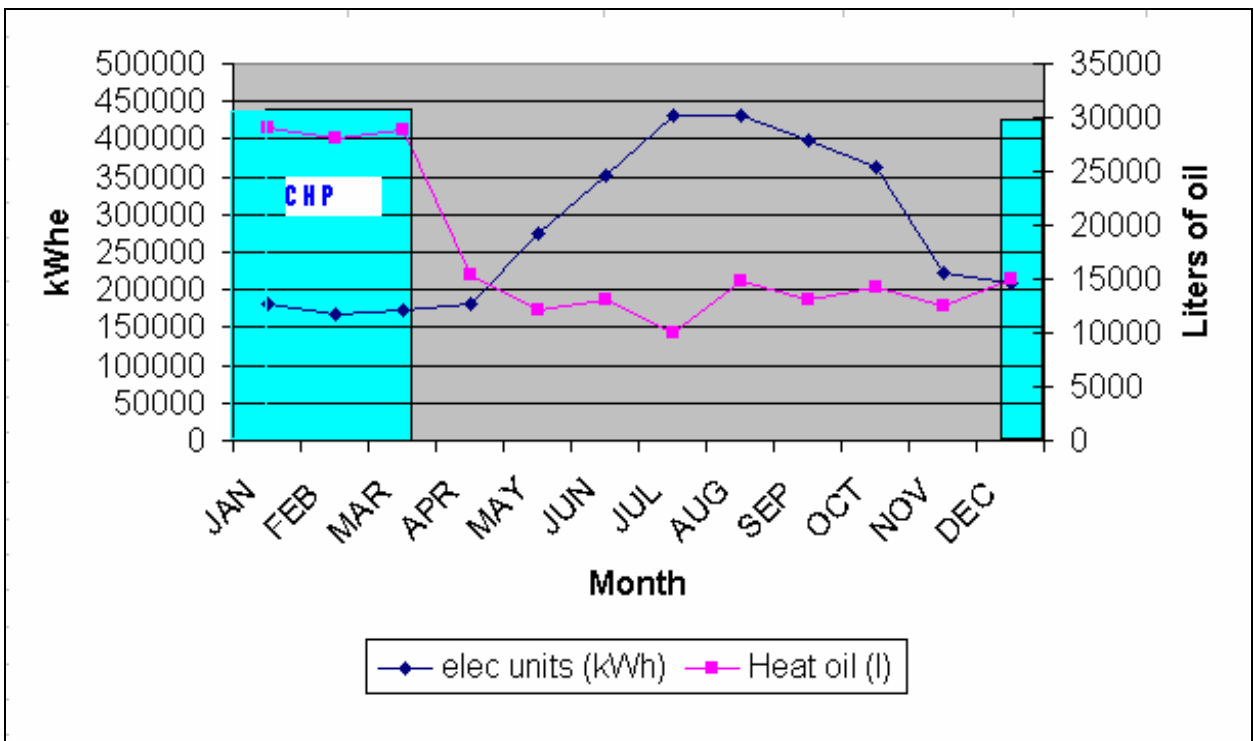

Chart 3. Case 1b. Specific Hotel where CHP is used only in cold season.

Seasonal Fuel Input	1121	MWh
Heating Season (incl. boiler produced LTHW)	3024	hours
Season Electricity consumption	728.7	MWh
Operating hours/year	3024	hours
Electricity Price	€ 107.5	€ / MWh
Fuel Price	€ 79.02	€ / MWh
Electricity export price	€ 69.88	€ / MWh
CHP availability	100 %	
O&M	€ 13.00	€/MWh
CHP Fuel	€ 93.42	€/MWh

Payback Period	CHP making loss	Heat Seasons (Years)
Energy Saving	1697.43	MWh

Table 16. Case 1b. Pre-2008 prices. CHP Fuel Gas Oil.

Seasonal Fuel Input	1121	MWh
Heating Season (incl. boiler produced LTHW)	3024	hours
Season Electricity consumption	728.7	MWh
Operating hours/year	3024	hours
Electricity Price	€ 115.79	€ / MWh
Fuel Price	€ 66.55	€ / MWh
Electricity export price	€ 69.88	€ / MWh
CHP availability	100 %	95
O&M	€ 13.00	€/MWh
CHP Fuel	€ 57.01	€/MWh

Payback Period	5.07	Heat Seasons (Years)
Energy Saving	1413.59	MWh

Table 17. Case 1b. Near Future prices. CHP Fuel Gas Oil. Electricity export price based on a net metering scheme.

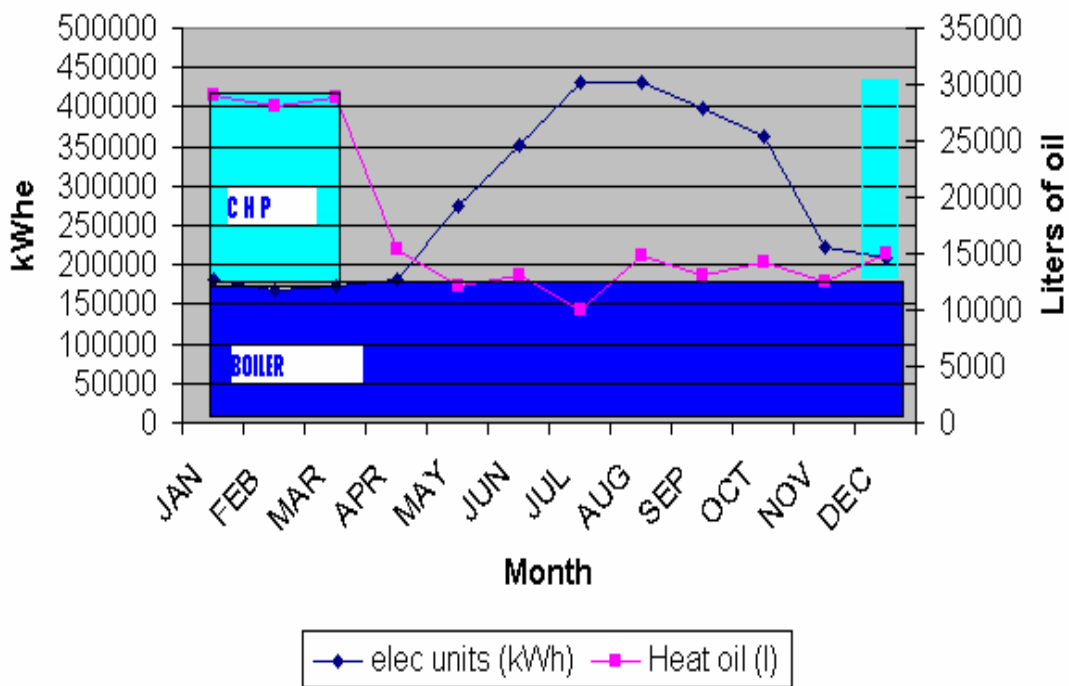

Chart 4. Case 1c) Specific Hotel where CHP provides excess heat requirements and a conventional boiler provides the heat base

Seasonal Fuel Input	1121 – Total 509.9 - CHP	MWh
Heating Season (incl. boiler produced LTHW)	3024	hours
Season Electricity consumption	728.7	MWh
Operating hours/year	3024	hours
Electricity Price	€ 107.50	€ / MWh
Fuel Price	€ 79.03	€ / MWh
Electricity export price	€ 69.88	€ / MWh
CHP availability	47 %	
O&M	€ 13.00	€/MWh
CHP Fuel	€ 93.42	€/MWh

Payback Period	CHP Making Loss	Heat Seasons (Years)
Energy Saving	774.53	MWh

Table 18. Case 1c. Pre-2008 Prices. CHP Fuel Gas Oil.

Seasonal Fuel Input	1121 – Total 509.9 - CHP	MWh
Heating Season (incl. boiler produced LTHW)	3024	hours
Season Electricity consumption	728.7	MWh
Operating hours/year	3024	hours
Electricity Price	€ 115.79	€ / MWh
Fuel Price	€ 66.55	€ / MWh
Electricity export price	€ 69.88	€ / MWh
CHP availability	100 %	
O&M	€ 13.00	€/MWh
CHP Fuel	€ 57.01	€/MWh

Payback Period	4.88	Heat Seasons (Years)
Energy Saving	648.53	MWh

Table 19. Case 1c. Near Future Prices. CHP Fuel Gas Oil. Electricity export price based on a net metering scheme.

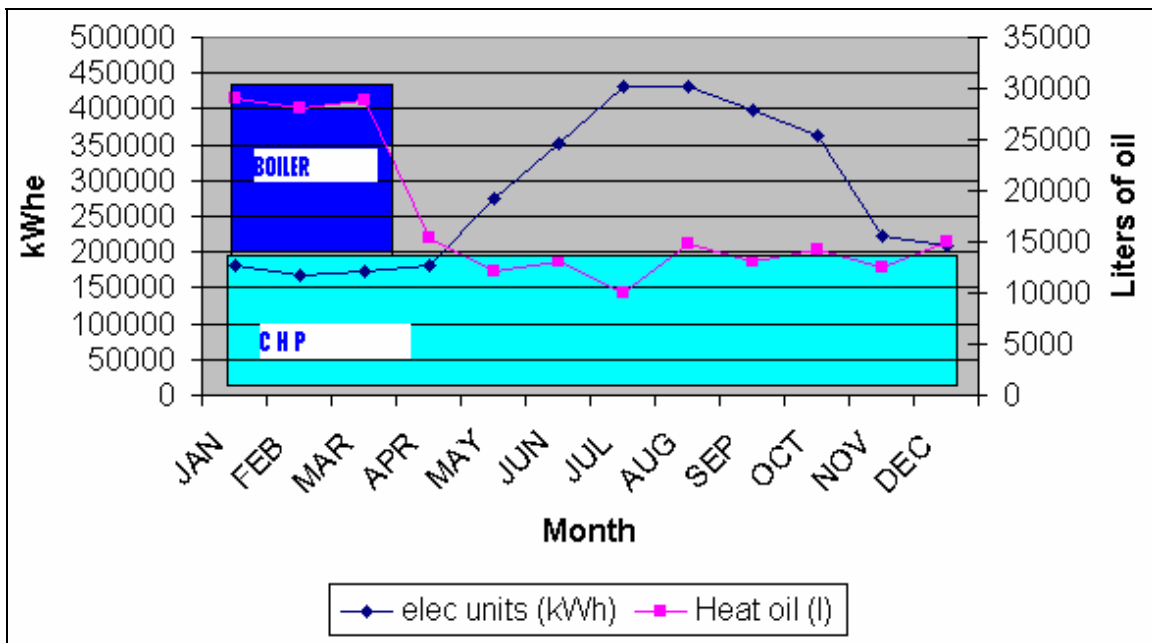

Chart 5. Case 1d. Specific Hotel with Conventional Boiler providing excess heat requirements and CHP providing heat base load.

Annual Fuel Input	1752	MWh
Heating Season (incl. boiler produced LTHW)	8760	hours
Season Electricity consumption	6800	MWh
Operating hours/year	8760	hours
Electricity Price	€ 107.50	€ / MWh
Fuel Price	€ 79.01	€ / MWh
Electricity export price	€ 69.88	€ / MWh
CHP availability	95 %	
O&M	€ 13.00	€/MWh
CHP Fuel	€ 93.42	€/MWh

Payback Period	CHP making loss	Years
Energy Saving	2526.62	MWh

Table 20. Case 1d. Pre-2008 Prices. CHP running on Gas Oil.

Annual Fuel Input	1752	MWh
Heating Season (incl. boiler produced LTHW)	8760	hours
Season Electricity consumption	6800	MWh
Operating hours/year	8760	hours
Electricity Price	€ 115.79	€ / MWh
Fuel Price	€ 66.55	€ / MWh
Electricity export price	€ 69.88	€ / MWh
CHP availability	95 %	
O&M	€ 13.00	€/MWh
CHP Fuel	€ 57.01	€/MWh

Payback Period	1.79	Years
Energy Saving	2113.13	MWh

Table 21. Case 1d. Near Future Prices. CHP running on Gas Oil. Electricity export price based on a net metering scheme).

2) Hotels by Category. Feasibility analysis was carried out on different heating hours scenarios since this is quite critical for the CHP payback period. So for these cases 8000 hours, 7000 hours and all year round (8760hrs) were considered. CHP fuel was always taken as Gas Oil.

Table 22. Pre-2008 Prices.

8000 hrs heat	Category	A	B	C
Hotel 1	Payback period (Years)	CHP making loss	CHP making loss	17.66
	Energy Savings (MWh)	3209.03	2709.40	439.53
Hotel 2	Payback period (Years)	CHP making loss	CHP making loss	8.82
	Energy Savings (MWh)	3670.20	1988.91	424.89
Hotel 3	Payback period (Years)	CHP making loss	CHP making loss	17.89
	Energy Savings (MWh)	2294.27	2189.4	250.32
Average	Payback period (Years)	CHP making loss	CHP making loss	14.79
	Energy Savings (MWh)	3057.83	2295.90	371.58

7000hrs heat	Category	A	B	C
Hotel 1	Payback period (Years)	CHP making loss	CHP making loss	CHP making loss
	Energy Savings (MWh)	3372.43	2847.62	462.32
Hotel 2	Payback period (Years)	CHP making loss	CHP making loss	CHP making loss
	Energy Savings (MWh)	3856.80	2090.71	446.93
Hotel 3	Payback period (Years)	CHP making loss	CHP making loss	CHP making loss
	Energy Savings (MWh)	2411.53	2301.36	263.34
Average	Payback period (Years)	CHP making loss	CHP making loss	CHP making loss
	Energy Savings (MWh)	3213.59	2413.23	390.86

8760hrs heat	Category	A	B	C
Hotel 1	Payback period (Years)	CHP making loss	CHP making loss	6.01
	Energy Savings (MWh)	3109.62	2625.31	425.68
Hotel 2	Payback period (Years)	CHP making loss	CHP making loss	4.38
	Energy Savings (MWh)	3556.68	1927.00	411.50
Hotel 3	Payback period (Years)	CHP making loss	CHP making loss	6.10
	Energy Savings (MWh)	2222.95	2121.30	242.40
Average	Payback period (Years)	CHP making loss	CHP making loss	5.50
	Energy Savings (MWh)	2963.08	2224.54	359.86

Table 23. Near Future Prices. Electricity export price based on a net metering scheme
(Scenario1)

8000 hrs heat	Category	A	B	C
Hotel 1	Payback period (Years)	2.13	1.91	1.47
	Energy Savings (MWh)	2646.14	2236.13	366.76
Hotel 2	Payback period (Years)	1.94	1.87	1.47
	Energy Savings (MWh)	3022.44	1644.78	354.35
Hotel 3	Payback period (Years)	2.08	1.88	1.42
	Energy Savings (MWh)	1895.72	1810.50	210.04
Average	Payback period (Years)	2.05	1.89	1.45
	Energy Savings (MWh)	2521.43	1897.14	310.38

7000 hrs heat	Category	A	B	C
Hotel 1	Payback period (Years)	2.79	2.42	1.78
	Energy Savings (MWh)	2726.48	2304.60	378.89
Hotel 2	Payback period (Years)	2.46	2.36	1.78
	Energy Savings (MWh)	3113.78	1695.90	366.08
Hotel 3	Payback period (Years)	2.72	2.38	1.17
	Energy Savings (MWh)	1954.24	1866.51	217.12
Average	Payback period (Years)	2.66	2.39	1.42
	Energy Savings (MWh)	2604.83	1955.47	320.70

8760 hrs heat	Category	A	B	C
Hotel 1	Payback period (Years)	1.81	1.64	1.30
	Energy Savings (MWh)	2597.00	2194.26	395.36
Hotel 2	Payback period (Years)	1.67	1.61	1.30
	Energy Savings (MWh)	2966.89	1613.53	347.19
Hotel 3	Payback period (Years)	1.77	1.62	1.26
	Energy Savings (MWh)	1859.94	1776.26	205.72
Average	Payback period (Years)	1.75	1.62	1.29
	Energy Savings (MWh)	2474.61	1861.35	316.09

Table 24. Near Future Prices. Electricity export price based on a feed in tariff scheme without bonus price (Scenario2).

8000 hrs heat	Category	A	B	C
Hotel 1	Payback period (Years)	9.38	8.81	5.20
	Energy Savings (MWh)	2646.14	2236.43	366.70
Hotel 2	Payback period (Years)	9.89	7.91	5.15
	Energy Savings (MWh)	3022.64	1644.78	354.35
Hotel 3	Payback period (Years)	8.30	8.31	4.91
	Energy Savings (MWh)	1895.72	1810.50	210.04
Average	Payback period (Years)	9.19	8.34	5.09
	Energy Savings (MWh)	2521.5	1897.24	310.36

7000 hrs heat	Category	A	B	C
Hotel 1	Payback period (Years)	CHP making loss	1023.96	13.19
	Energy Savings (MWh)	2726.48	2304.60	378.89
Hotel 2	Payback period (Years)	CHP making loss	73.45	12.95
	Energy Savings (MWh)	3113.78	1695.90	366.08
Hotel 3	Payback period (Years)	128.51	113.88	10.73
	Energy Savings (MWh)	1954.24	1866.51	217.12
Average	Payback period (Years)	CHP making loss	403.76	12.29
	Energy Savings (MWh)	2598.17	1955.67	320.70

8760 hrs heat	Category	A	B	C
Hotel 1	Payback period (Years)	5.22	5.51	3.82
	Energy Savings (MWh)	2597.00	2194.26	359.36
Hotel 2	Payback period (Years)	5.93	5.13	3.79
	Energy Savings (MWh)	2966.89	1613.53	347.19
Hotel 3	Payback period (Years)	5.30	5.32	3.47
	Energy Savings (MWh)	1859.94	1776.26	205.72
Average	Payback period (Years)	5.48	5.32	3.69
	Energy Savings (MWh)	2474.61	1861.35	304.09

Table 25. Case 2. Near Future Prices. Electricity export price based on a feed in tariff scheme with bonus price (Scenario3).

8000 hrs heat	Category	A	B	C
Hotel 1	Payback period (Years)	1.82	1.66	1.32
	Energy Savings (MWh)	2646.14	2236.13	366.76
Hotel 2	Payback period (Years)	1.68	1.63	1.32
	Energy Savings (MWh)	3022.64	1644.78	354.35
Hotel 3	Payback period (Years)	1.79	1.60	1.37
	Energy Savings (MWh)	1895.72	1810.50	210.04
Average	Payback period (Years)	1.76	1.63	1.34
	Energy Savings (MWh)	2521.50	1897.14	310.38

7000 hrs heat	Category	A	B	C
Hotel 1	Payback period (Years)	2.29	2.03	1.57
	Energy Savings (MWh)	2726.48	2304.60	378.89
Hotel 2	Payback period (Years)	2.06	2.00	1.56
	Energy Savings (MWh)	3113.78	1695.90	366.08
Hotel 3	Payback period (Years)	2.24	2.01	1.62
	Energy Savings (MWh)	1954.24	1866.51	217.12
Average	Payback period (Years)	2.20	2.01	1.58
	Energy Savings (MWh)	2598.17	1955.67	320.70

8760 hrs heat	Category	A	B	C
Hotel 1	Payback period (Years)	1.58	1.46	1.19
	Energy Savings (MWh)	2597.00	2194.26	359.36
Hotel 2	Payback period (Years)	1.47	1.43	1.18
	Energy Savings (MWh)	2966.89	1613.53	347.19
Hotel 3	Payback period (Years)	1.56	1.45	1.32
	Energy Savings (MWh)	1859.94	1776.26	205.72
Average	Payback period (Years)	1.54	1.45	1.23
	Energy Savings (MWh)	2474.61	1861.35	304.09

Table 26. Case 2. Near Future Prices. Electricity export price based on a feed in tariff scheme with bonus price on 50% of the electricity exported (Scenario 4).

8000 hrs heat	Category	A	B	C
Hotel 1	Payback period (Years)	3.05	2.79	2.11
	Energy Savings (MWh)	2646.14	2236.13	366.76
Hotel 2	Payback period (Years)	2.87	2.71	2.10
	Energy Savings (MWh)	3022.64	1644.78	354.35
Hotel 3	Payback period (Years)	2.95	2.68	2.15
	Energy Savings (MWh)	1895.72	1810.50	210.04
Average	Payback period (Years)	2.96	2.73	2.12
	Energy Savings (MWh)	2521.50	1897.14	310.38

7000 hrs heat	Category	A	B	C
Hotel 1	Payback period (Years)	4.63	4.05	2.80
	Energy Savings (MWh)	2726.48	2304.60	378.89
Hotel 2	Payback period (Years)	4.22	3.89	2.79
	Energy Savings (MWh)	3113.78	1695.90	366.08
Hotel 3	Payback period (Years)	4.40	3.95	2.81
	Energy Savings (MWh)	1954.24	1866.51	217.12
Average	Payback period (Years)	4.42	3.96	2.80
	Energy Savings (MWh)	2598.17	1955.67	320.70

8760 hrs heat	Category	A	B	C
Hotel 1	Payback period (Years)	2.43	2.26	1.78
	Energy Savings (MWh)	2597.00	2194.26	359.36
Hotel 2	Payback period (Years)	2.31	2.20	1.77
	Energy Savings (MWh)	2966.89	1613.53	347.19
Hotel 3	Payback period (Years)	2.36	2.23	1.82
	Energy Savings (MWh)	1859.94	1776.26	205.72
Average	Payback period (Years)	2.37	2.23	1.79
	Energy Savings (MWh)	2474.61	1861.35	304.09

4.5 Hotel Sector Conclusions. In all cases analyzed, the pre-2008 situation showed a high degree of economic non-feasibility for most cases probably because of a number of reasons including the electricity prices and also the Customs Department interpretation that zero excise duty rates, for fuel used in the generation of electricity applied only to the National Electricity provider. For the pre-2008 scenario all cases showed positive primary energy savings however no scenario showed economic feasibility. When addressing Hotels by category, Analysis 2, under the pre-2008 scenarios questionable economic feasibility resulted in Category C hotels, where CHP fuel costs would be limited as the size of the required engine would have been small. Questionable because as can be seen in Table 22 economic feasibility is achieved if the unit runs for 8760 hours a year, i.e. with minimal shutdown.

In the near future scenarios where (i) the excise duty regime shown in Table 10 is enforced to CHP installations, and (ii) the grid electricity price reflects more the generating costs, than CHP becomes both technically and economically viable. When analyzing the results in scenarios 1(a) to 1(d) payback periods for all cases are very attractive. Table 27 summarizes these results. This analysis again shows the economical feasibility is earlier achieved when the unit is made use of as much as possible i.e. scenarios 1(a) and 1(d).

	Payback period (years)	Primary Energy Savings (MWh)
Near Future Scenario		
Case 1(a)	1.81	2752.88
Case 1 (b)	5.07	1413.59
Case 1(c)	4.88	648.53
Case 1(d)	1.79	2113.13

Table 27.

When analyzing data provided from all the hotels, i.e. case 2, again it is evident that economic feasibility depends on (i), the annual running hours of the CHP; (ii) amount of heat load required out of the CHP thus determining its size and (iii) the scheme adopted for electricity export pricing. For scenario 1, where net metering is considered (Table 23), the running hours of the machine did not affect the economic feasibility of the investment which resulted as very attractive of approximately 1 year. Scenario 2, where a feed in tariff very much less than the standard electricity price was considered (Table 24), proved unfeasible for most of the cases. When analyzing scenarios 3 and 4 , where a bonus price is added to the feed in tariff (Table 25 & 26), all cases showed economic feasibility even when the CHP running hours is reduced to 7000 hours.

5. Potential in the Industry Sector

Industries with high heating requirements which might consider the use of CHP are limited on the Islands. Three types were identified for possible technical feasibility: the beverage industry; laundries; and the packaging industry. However the industrial sectors which were analysed were the beverage industry and the laundries. The packaging industry chose not to cooperate with this study hence results mentioned hereunder do not include data from this sector.

As the number of factories in the sector examined is very small, for the official report, the Malta Resources Authority could not distinguish between sectors due to data protection issues.

5.1 Data. The consumption data for heating fuel and electricity consumption with the cost for consumption figure, the type of fuel used and the main application, the number of operating days and hours was received by the Authority from the industries identified with a technical feasibility for cogeneration. The analysis is done (i) for the period pre-2008 on fuel prices and electricity bills, as provided by each firm and (ii) for the scenarios described in 2.4.6 assuming same load requirements as those submitted for 2007 by the industries concerned,

5.2 Electricity price. The electricity tariffs for the Industrial sector can be reviewed from Section 2.4.2. As can be deduced the overall net unit price varies from industry to industry depending on their consumption, operation hours and metering type. Hence the industries were divided into those with high heat to power ratio and those with low heat to power ratio.

5.3 Fuel Price. Fuel pricing for Industry varies according to type of fuel. Pre-2008 the main fuels used were Light Heating Oil (LHO)⁷, and Thin Fuel Oil which is a blend of Heavy Fuel Oil and Light Heating Oil. As regards to the future projections, the use of 0.1% Sulphur Gas Oil and Thin fuel oil are analyzed (LHO is not considered as a new legislation was enforced introducing the availability of Gas Oil at 0.1 per cent Sulphur.. The availability of cheaper Thin Fuel Oil is still considered for future scenarios and possibly would still be preferred over 0.1% Sulphur Gas Oil due to price. As regards fuel prices for the ‘near future’ the price was based upon annual average of fuel from 2005 to 2008. Table 28 summarizes the price used for this study.

Industrial Consumers Prices	Pre-2008 Electricity price (€/MWh)	Near Future Electricity price (€/MWh) ⁸	Pre-2008 fuel Price (€/MWh)		Near Future fuel price (€/MWh)	
			Gas Oil	Thin FO	Gas Oil	Thin FO
High heat to power ratio	27.14	131.92	93.46	27.90	57.01	32.05
Low heat to power ratio	68.18	99.54	93.46	27.66	57.01	28.82

Table 28.

5.4 Analysis. Due to the structure of the electricity pricing system, the electricity prices for industry vary a lot. Pre-2008 the section of the industry, with electricity consumption in the region of 637 MWh paid €27.14 per MWh. For more electricity intensive industry the price reached €68.18 per MWh. This has changed in the new electricity tariff system as can be deduced from Table 28.

⁷ LHO is “heavy oil” as defined in Chapter 27 of the Combined Nomenclature (Council Regulation (EEC) No.2658/87.

⁸ Electricity Tariff depends on consumption. Tariff are based on annual average consumption.

To distinguish between industries for this study the choice fell on the heat to power ratio. Hence industry is divided between those having low (approximately 1 or less) heat to power ratio and those with higher. Tables 29 and 30 show how feasibility of CHP varies between industries of high or low heat to power ratio, using different either Gas Oil or Thin Fuel Oil⁹ under pre-2008 and future scenarios mentioned in Section 2.4.7

Industry with high heat to power ratio				
Assuming an annual fuel input of 6458.92 MWh, and annual electricity consumption of 637.26 MWh, an annual heating and electricity requirement season of 2250 hours and a CHP availability of 95%.				
	Thin Fuel Oil		Gas Oil	
	Payback period (years)	Primary Energy Savings (MWh)	Payback period (years)	Primary Energy Savings (MWh)
Pre-2008	12.55	9185.24	CHP Making Loss	9185.24
Future Scenario 1	8.10	7534.59	CHP Making Loss	7534.59
Future Scenario 2	10.80	7534.59	CHP Making Loss	7534.59
Future Scenario 3	3.22	7534.59	13.26	7534.59
Future Scenario 4	4.96	7534.59	CHP Making Loss	7534.59

Table 29

5.5. Industrial Sector Conclusions. For both types of industry if the CHP fuel used is Gas Oil the CHP running costs would be higher than conventional power system

⁹ Though the writers of this report did not have exact information if CHP units running on Thin Fuel Oil were available on the market for the purpose of this study it was assumed that these were available and given an Operation and Maintenance cost double those running on Gas Oil.

cost, hence making CHP economically unfeasible. The fuel used by the industry to run their boilers is cheap, compared to Gas Oil, approximately € 27 / MWh in pre-2008 period. If the CHP engine is to run on Gas Oil, CHP would never be economically feasible, as Gas Oil is over €0.88 / liter. However if CHP engines are designed to run on the fuel available to Industry then CHP would be economically feasible.

Feasibility of CHP running on Thin Fuel Oil is dependant on the market conditions and the size of the CHP. For industry with a high heat to power ratio, a large machine, enough to cover their heat requirement, would prove to be economically unfeasible unless a bonus price is added to the electricity feed in tariff as these industry would have a substantial amount of electricity to export.

Industry with low heat to power ratio				
Assuming an annual fuel input of 16838.89 MWh, and annual electricity consumption of 11 000 MWh, an annual heating and electricity requirement season of 6768 hours and a CHP availability of 95%,				
	Thin Fuel Oil		Gas Oil	
	Payback period (years)	Primary Energy Savings (MWh)	Payback period (years)	Primary Energy Savings (MWh)
Pre-2008	3.65	23969.60	CHP Making Loss	23969.60
Future Scenario 1	1.86	19683.91	CHP Making Loss	19683.91
Future Scenario 2	3.90	19683.91	CHP Making Loss	19683.91
Future Scenario 3	1.61	19683.91	CHP Making Loss	19683.91
Future Scenario 4	2.21	19683.91	CHP Making Loss	19683.91

Table 30

For industry with a low heat to power ratio economic feasibility is achieved even with pre-2008 market conditions as the major part of the electricity requirement would be delivered by a CHP unit run on cheap fuel. These industries would not export electricity thus under a net metering system economic feasibility is achieved as in the pre-2008 scenario. With a feed in tariff system where a bonus price is added to the standard electricity price for electricity put into the grid, feasibility is achieved in a period acceptable to the Industry as the industry (with high electrical load) offsets costs through export of its generated electricity to the grid.

6. Potential of the Educational Sector.

Schools, senior colleges and universities in Malta operate between October till the end of June. The layout of educational establishments in Malta is designed to include large windows, thus heating of the classrooms was never an issue. However, all rooms would be equipped with ceiling fans for the warm months of May and June. Hence, as the heating/cooling load is minimal, the potential for co-generation is negligible.

6.1 Analysis. The only entity which has a heated pool is the University. Table 31 and 32 summarise the results for feasibility at the Pool Complex. In Malta, government entities pay the full commercial electricity rate without rebates and including the fuel surcharge. The electricity and fuel prices used for pre-2008 were the figures submitted by the management of this entity. The future fuel price was based upon the average diesel price between 2005 and 2008 rising to € 66.55 per MWh. No rebate was associated with this fuel when used for conventional boiler heating purposes as similarly to electricity rates Government Institutions are not eligible to rebates, however CHP fuel is duty free at € 57.01 per MWh. Near future electricity prices depends on the consumption however it is estimated as €133 per MWh. Future scenarios are those as explained in Section 2.4.7.

6.2 Conclusion. As can be seen in Tables 31 and 32, and consistent with cases where there is high heat to power ratio, CHP under pre-2008 conditions is not viable as the CHP running costs would be more than conventional system running costs. CHP would only become viable as indicated in future scenarios when (i) CHP operators are supplied with excise duty free fuel to run their engines, (ii) the import electricity price reflects the generated price at the power plants, and (iii) a tariff scenario is devised where the rate of return upon investment would be really attractive, such as the introduction of a ‘bonus price’ upon CHP-generated electricity.

Annual Fuel Input	2780.2	MWh
Heating Season (incl. boiler produced LTHW)	8040	Hours
Annual Elec. consumption	541.2	MWh
Operating hours/year	8760	Hours
Electricity Price	€ 154.70	€ / MWh
Fuel Price	€ 100.30	€ / MWh
Electricity export price	€ 69.88	€ / MWh
CHP availability	95 %	
O&M	€ 13.00	€/MWh
CHP Fuel Price	€ 93.46	€ / MWh
Payback Period	CHP making loss	Years
Energy Saving	4122.26	MWh

Table 31. Pre-2008 prices

Annual Fuel Input	2780.2	MWh
Heating Season (incl. boiler produced LTHW)	8040	Hours
Annual Elec. consumption	541.2	MWh
Operating hours/year	8760	Hours
Electricity Price	€ 133	€ / MWh
Fuel Price	€ 66.55	€ / MWh
CHP availability	95 %	
O&M	€ 13.00	€ / MWh
CHP Fuel Price	€ 57.01	€ / MWh
	Payback Period (years)	Primary Energy Savings (MWh)
Future Scenario 1	3.85	3395.17
Future Scenario 2	9.93	3395.17
Future Scenario 3	1.46	3395.17
Future Scenario 4	2.55	3395.17

Table 32. Near Future scenario. CHP running on Gas Oil

7. Potential of the Health Care (Hospital) Sector.

In Malta there are four major public Hospitals. The operation of the former major hospital, St. Luke's, has declined considerably since June 2007 after the opening of the new major public hospital, Mater Dei. Unfortunately, this has put this analysis for hospitals in a disadvantageous situation, since data from St. Luke's Hospital is no longer significant, given that the operations of this hospital have (i) drastically reduced and (ii) will considerably change in the near future. Furthermore, data of the new major hospital Mater Dei is not available in full, since this has been in operation for just 17 months. Alternatively the study will be considering the two other hospitals, usually dedicated to specific illnesses, Mount Carmel and Sir P. Boffa.

7.1 Electricity and Fuel Prices. Similarly to the Educational Sector, hospitals pay full commercial electricity rates without rebates and including the fuel surcharge. As done in the Industry sector it was clear from the data supplied that one hospital had a significantly higher heat to power ratio. And hence it was decided to distinguish between them in this manner, as done in the Industrial Sector. The electricity and fuel prices used for 'pre-2008' were the figures submitted by the management of these entities. Future fuel prices were kept same as those used in Section 6 for the Government University pool, whilst electricity prices were adjusted according to the new electricity tariff system. Table 33 summarizes these figures. Future scenarios were considered as in all the other sectors as quoted in 2.4.7.

7.2 Analysis. As already stated in 7.1 above, the two hospitals taken for consideration were distinguished by their heat to power ratio. The hospital with a high heat to power ratio, approximately 6, uses Light Heating Oil¹⁰ as their source of combustion, whilst the hospital with a low heat to power ratio (< 1), which has much more limited operation, uses Gas Oil. In the analysis, the hospital with a high heat to

¹⁰ It is assumed that for future scenarios this fuel is not available and only Gas Oil would be available, either rebated or not.

power ration was analyzed using different CHP fuel to investigate whether this had an effect on the feasibility of the CHP as had occurred in the Industrial Sector. Tables 34 to 38 indicate the results achieved.

Hospital Electricity and Fuel Prices	Pre-2008 Electricity price (€/MWh)	Future Electricity price (€/MWh) ¹¹	Pre-2008 fuel Price (€/MWh)		Future fuel price (€/MWh)	
			Gas Oil	Light Heating Oil	Gas Oil for Fossil Fuel Boiler	Duty Free Gas Oil for CHP
High heat to power ratio	141	167.90	93.46	79.01	66.55	57.01
Low heat to power ratio	141	133.00	100.31	N/A	66.55	57.01

Table 33

Annual Fuel Input	9121.9	MWh
Heating Season (incl. boiler produced LTHW)	8760	hours
Annual Electricity consumption	1155.4	MWh
Operating hours/year	8760	hours
Electricity Price	€ 141.00	€/ MWh
Fuel Price	€ 79.01	€/ MWh
Electricity export price	€ 69.88	€/ MWh
CHP availability	95 %	
O&M	€ 13.00	€/MWh
CHP Fuel	€ 93.44	€/MWh

Payback Period	CHP making loss	Years
Energy Saving	13054.01	MWh

Table 34. Hospital with high heat to power ratio. Pre-2008 prices. CHP fuel Gas Oil.

¹¹ Electricity Tariff depends on consumption. Tariff are based on annual average consumption.

Annual Fuel Input	9121.9	MWh
Heating Season (incl. boiler produced LTHW)	8760	hours
Annual Electricity consumption	1155.4	MWh
Operating hours/year	8760	hours
Electricity Price	€ 141.00	€ / MWh
Fuel Price	€ 79.01	€ / MWh
Electricity export price	€ 69.88	€ / MWh
CHP availability	95 %	
O&M	€ 13.00	€/MWh

Payback Period	CHP making loss	Years
Energy Saving	13054.01	MWh

Table 35. Hospital with high heat to power ratio. Pre-2008 prices. CHP fuel Light

Heating

Annual Fuel Input	308.1	MWh
Heating Season (incl. boiler produced LTHW)	8760	hours
Annual Electricity consumption	397.76	MWh
Operating hours/year	8760	hours
Electricity Price	€ 141.00	€ / MWh
Fuel Price	€ 100.31	€ / MWh
Electricity export price	€ 69.88	€ / MWh
CHP availability	95	
O&M	€ 13.00	€/MWh

Payback Period	2.53	Years
Energy Saving	446.51	MWh

Table 36. Hospital with low heat to power ratio. Pre-2008 prices. CHP fuel Gas Oil.

Hospital with high heat to power ratio		
Assuming an annual fuel input of 9121.9 MWh, and annual electricity consumption of 1155.4 MWh, an annual heating and electricity requirement season of 8760 hours and a CHP availability of 95%,		
	Payback Period (years)	Primary Energy Savings (MWh)
Future Scenario 1	4.17	10790.68
Future Scenario 2	1.56	10790.68
Future Scenario 3	1.45	10790.68
Future Scenario 4	2.42	10790.68

Table 37.

Hospital with low heat to power ratio		
Assuming an annual fuel input of 308.1 MWh, and annual electricity consumption of 397.76 MWh, an annual heating and electricity requirement season of 8760 hours and a CHP availability of 95%,		
	Payback Period (years)	Primary Energy Savings (MWh)
Future Scenario 1	1.31	377.72
Future Scenario 2	3.49	377.72
Future Scenario 3	1.16	377.72
Future Scenario 4	1.74	377.72

Table 38

7.3 Hospital Sector Conclusion. As had resulted in the Industrial Sector, the hospital having a considerably lower heat to power ratio shows that it was feasible to operate via CHP even in the pre-2008 market conditions. This similarity with Industrial Sector did not match for the hospital with the high heat to power ratio, due to the use of different fuels. For the pre-2008 scenario, using Light Heating Oil as a fuel kept the

CHP running costs higher than conventional methods of heating. This happened because the difference between the pre-2008 prices of Gas Oil and Light Heating Oil were not enough to make the difference.

However, when in the 'near future' scenario (i) the availability of Light Heating Oil is restricted to low sulphur Gas Oil, (ii) the excise duty for CHP fuel is zero and (iii) electricity prices are maintained to reflect more the actual price, the payback period becomes feasible for all future scenarios.

8. Potential of the Waste Sector

It has been only recently that waste treatment plants are being upgraded and that the possibility of CHP is being considered. Solid waste in Malta is tackled through Wasteserv Malta Ltd. which was established in November 2002. The company is responsible for organizing, managing and operating integrated systems for waste management including integrated systems for minimization, collection, transport, sorting, reuse, utilization, recycling, treatment and disposal of solid and hazardous waste.

At the main waste treatment plant, Wasteserv, shall install two biogas engines with maximum generating capacity of 1.74 MW, fired from the biogas generated during the digestion process. It is expected that 640Nm³/hr of biogas are generated with 60 per cent methane concentration generating 0.92 MW (equivalent to 8GWh/annum). The thermal energy taken from the engine cooling water shall be used for heating the waste suspension via two heat exchangers and provide heat also to a pool located in a centre for people with special requirements located nearby. The system should run 330 days a year.

Another CHP plant shall be put in service by the Water Services Corporation (WSC). WSC is the public company in Malta responsible for the tap water supply operations and maintaining the water piping network. WSC are also in charge of the disposal of liquid waste. In the coming years a new liquid waste plant shall be built which shall include three, 330kW, gas engines fitted with heat recovery exchangers for hot water production. This hot water production will keep the anaerobic sludge digesters up an optimal temperature. It is estimated that 649 Nm³/hr of gas will be generated supplying enough energy to run the engines at maximum load.

If the fuel supply cost in this sector is considered as 'zero', the rate of return on the CHP plant would be very small i.e. in terms of months. This assumes that the plant runs for 11 months a year and that it would still require some form of heating for its process either through a hot water boiler or through electric heating.

9 The Use of Absorption Chillers

As clarified in previous sections, operators, of some commercial and industrial entities in Malta have a low constant heat requirement throughout the year, and then an extensive requirement of electrical power for cooling purposes between May and October.

This energy profile would suggest the use of absorption chillers to generate cool environment from a heat source. However, for this report, the technology was not investigated in detail due to (i) the lack of practical technological and cost data and (ii) more importantly, the likely possibility that heat deriving from renewable sources to provide the heat requirements for an absorption chiller would be more viable than heat provided from a conventional boiler or from CHP.

In the paragraphs below an approximate exercise is raised to show that with near future market prices absorption chiller running costs would prove slightly viable.

In this short exercise the following parameters are assumed:

Power Station efficiency	31.4 %
Power Transmission losses	5 %
Coefficient of Performance – Conventional Electric Chiller	3.5
Coefficient of Performance – Multi Stage Absorption Chiller	1
Convention Boiler efficiency	75 %
CHP heat efficiency	50 %

Table 39. Operational assumptions for absorption chillers consideration.

Chart 6 gives a pictorial view of what 100 MW input in various technologies can achieve in cooling load. 100 MW fuel energy in a power utility achieve 102.5 MW of cooling load, whilst a CHP 100 MW of fuel energy generate 50 MW of cooling load plus around 30 to 40 MW of electrical load.

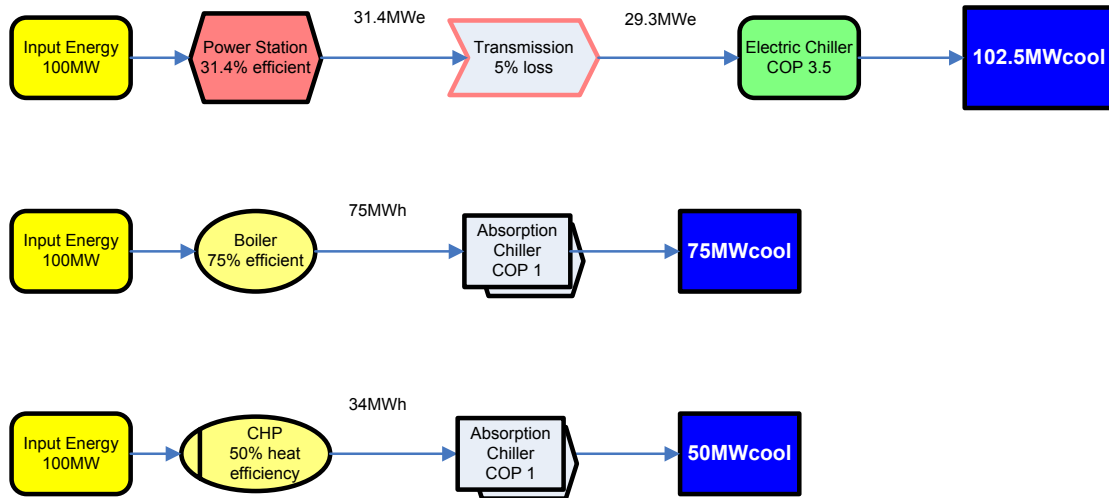

Chart 6

Using chart 6, for a simple analysis of absorption chilling, it can be seen that with current technologies 50 MW of cooling load can be obtained by an electric chiller using 14.29 MW_e. At ‘future’ prices (assuming 122.2 €/MWh) an average Hotel would generate this cooling load for an hour for €1747. To generate this amount of cooling load a CHP would require 100 MW of fuel load at around €5701 per hour. Based on this example the electricity generated would be around 35 MW, equivalent to a market cost of around €4277 per hour. CHP costs would be €5701 and conventional costs would be €1747 plus €4277 equalling €6024. This simple analysis shows that there could be economic feasibility with near future electricity and fuel prices. However, the figures totally differ if electricity and fuel prices are returned to the pre-2008 market, as feasibility would never be reached when CHP fuel costs reach €9342 per hour.

10. Conclusions

As can be seen from the feasibility Tables of the various sectors analyzed, the Primary Energy Savings were always positive, indicating that CHP is technically feasible and advantageous. However, when analyzing the same tables and sectors for economic feasibility at the pre-2008 market conditions, this will only prove positive when the CHP equipment is either:

- used in entities with low heat to power requirements, or;
- run using cheaper Thin Fuel Oil instead of Gas Oil. Thin Fuel Oil is currently used in the Industry only due to the visual impact of its use, and due to the high share of heavy fuel oil in its blend.
- installed at waste re-generation sites, where the fuel costs are “nil”.

When the ‘near future’ scenario Tables are analyzed, including an updated excise duty regime, and with higher electricity import and export prices, and lower CHP fuel prices, CHP becomes viable in all scenarios except for the Industry Sector. This latter sector’s non-feasibility is due to the availability of cheap Thin Fuel Oil, a blend of heavy fuel oil and gas oil. In Industry, feasibility resulted positive when it was assumed that the CHP engine could ‘run’ on Thin Fuel Oil. With this assumption, in industry with a low heat to power ratio, CHP proved feasible in all scenarios. When Gas oil is considered as CHP fuel, the only option showing economic feasibility was in Industry with a high heat to power ratio, and only in Scenario 3, i.e. with a large bonus price on generated electricity. However as the authors of the report did not have information if this equipment, i.e. CHP engines using thin fuel oil, is available, it was concluded that conventional CHP engines are economically unfeasible in Industry.

Analyzing the four ‘future’ scenarios it can be distinctly seen that both electricity pricing systems i.e. net metering (scenario 1) and a feed in tariff system with a bonus price on export (scenarios 3 & 4), could prove feasible in Hotels and institutions like Hospitals. The new electricity pricing system definitely aided to make CHP more feasible especially in the light that the pre-2008 prices extensively differed from the specific electricity cost

in Malta stated by the consultants to the Malta Resources Authority, Lahmeyer International GmbH, in their study 'Energy Interconnection Study for Malta'.

Table 40 shows that 71 GWh in Primary Energy Savings can be achieved with the installation of 42 CHP installations totaling 4.3 MW. This table does not include CHP from the Waste Plants, which would increase the figure of Primary Energy Savings to 125 GWh, and CHP in Industry running on thin fuel oil which would further increase the total figure to 150 GWh (see Table 40)

With the introduction of CHP units and their positive primary energy savings, CO₂ emissions on a National level would decrease on the basis of better generation efficiency. Enemalta Corporation (EMC) would also reap benefits of these primary energy saving as it would decrease its CO₂ footprint. CO₂ reduction levels are given in Tables 40 and 41. However it has to be noted the CO₂ emission resulting from co-generation units dispersed over the island have to be included within the emissions that Malta is bound not to increase beyond 5% over its 2005 level by 2020.

Way forward. In order for future CHP market scenarios to work efficiently, the Malta Resources Authority must make sure that the electricity generated by CHP units has actually been generated from high efficiency CHP as directed by the European Directive 2004/8/EC. These units generated must be certified and upon these 'certified' generated units, Guarantee of Origin (GOO) should be issued so that these units are given preference or bonus rates and the CHP fuel given proper rebates. Hence the Government could have two ways forward: either scenario 1 or scenario 4 with a system established on how to operate a scheme whereby high efficient CHP generators of electricity receive their fuel free of excise duty

Type of Industry	No. of CHP units installed ¹²	Total National Primary Energy Savings MWh	Total Energy not used by EMC MWh	Total Electricity Not Generated by EMC € ¹³	National CO2 Reductions Tons	CO2 Reductions of EMC Tons	CO2 Increase Sites Tons	Feasibility using future scenarios 1 and 4 respectively. (Years) ¹⁴		Average CHP Capital Cost per installation €
								1	4	
Category A Hotel	12	29 696	43 828	2 031 655	8378	12 092	3 714	1.75	2.37	107 816
Category B Hotel	12	22 336	32 559.	1 509 316	6297	8 983	2 687	1.62	2.23	80 098
Category C Hotel	15	4 561	6 171	286 002	1280	1702	422	1.28	1.74	12 145
University Pool	1	3395	5 443	252 332	964	1502	538	3.85	2.55	146 337
Hospital with high heat to power ratio	1	10 791	16 944	785 470	3058	4675	1617	4.17	2.42	455 524
Hospital with low heat to power ratio	1	378	515	23871	106	142	369	1.31	1.74	13 844
Totals	<i>42</i>	<i>71 156</i>	<i>105 460</i>	<i>4 888 647</i>	<i>20 082</i>	<i>29 097</i>	<i>9 348</i>			

Table 40 Projected installations.

¹² The figures for Hotels include all Category A Hotels and 50 percent of Category B and C Hotels.

¹³ These costs are calculated using the Lahmayer sent out electricity cost figure of 148 €/ MWh.

¹⁴ Feasibility study calculated as indicated in the various sections of this document.

Type of Industry	No. of CHP units installed ¹⁵	Total National Primary Energy Savings MWh	Total Energy not used by EMC MWh	Total Electricity Not Generated by EMC € ¹⁶	CO2 reductions of EMC Tons	Feasibility using future scenarios 1 and 4 respectively. (Years) ¹⁷		CHP Capital Cost per installation €
Previous total	42	71 156	105 460	4 929 987	29 097			
Industry with high heat to power ratio ¹⁸	2	15 069	24 715	1 145 690	6 819	8.99	5.26	1 293 424
Industry with low heat to power ratio	1	19 684	28 398	1 487 315	7 835	3.61	2.18	1 116 424
CHP from Waste	2	44 592	50 953	2 352 694	14 058			
Total	46	150 501			57 809			

Table 41 Projected installations – less likely.

¹⁵ These figures are assumptions of the officers writing this document.

¹⁶ These costs are calculated using the Lahmayer sent out electricity cost figure of 148 €/ MWh.

¹⁷ Feasibility study calculated as indicated in the various sections of this document.

¹⁸ Industrial CHP running on Thin Fuel Oil